

SUGGESTED PAD LAYOUT

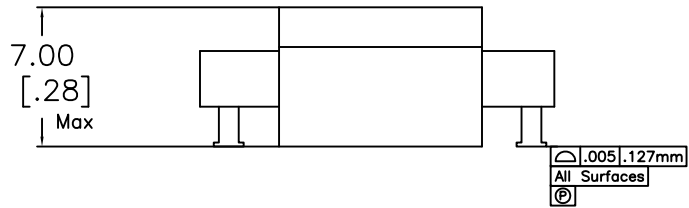

Schematic

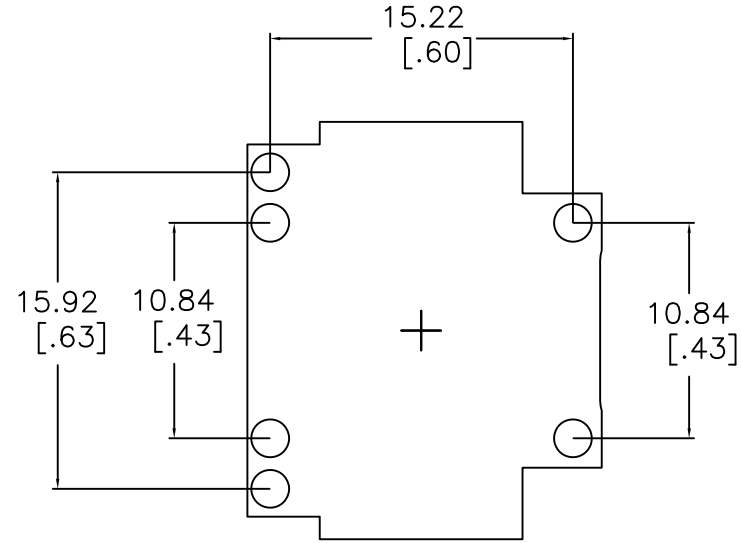
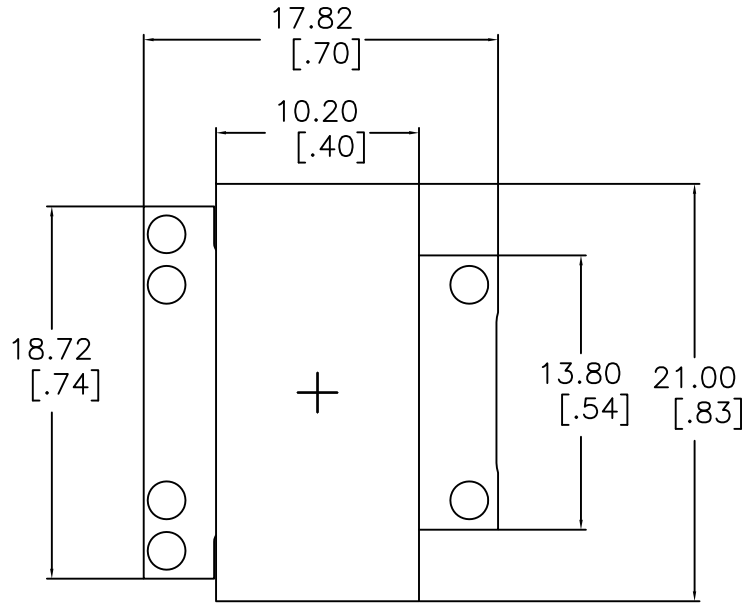
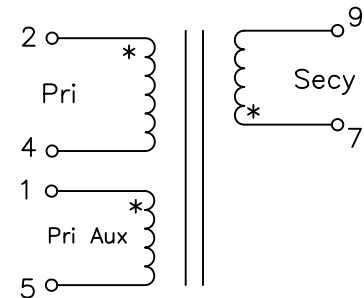

NOTES:

1. TURNS RATIO [7-9] : [2-4] = 0.167 +/-2% || [1-5] : [2-4] = 0.416
2. DCR [2-4]=60 mohm Nom, [7-9]= 1.30 mohm Nom.[1-5]=30 mohm Max.
3. Inductance [2-4]=30.0 uH Nom, 100KHz, 1.0 VRMS @ 25C
4. Leakage Inductance [2-4] Short [7-9] = 200nH Nom @100 KHz
5. Dielectric Strength [2,4-1,5] to [7-9] 1500 VDC, [2-4] to CORE 1500 VDC, [7-9] to CORE 500 VDC
6. Weight 6.8 grams Max | RoHS & REACH Compliant

No.	DESCRIPTION	REVISIONS	DATE	APPR
CHAMPS TECHNOLOGIES				
DRAWN		SIGN	DATE	Champs No. 20F1-1202-05-30R
CHKD		HE	10.07.13	Customer
APPR				Part #:   ISSUE A   REV 00
				SIZE   SCALE 3:1