

- NOTES:
- DCR [2-5]=4.0 mohm Nom, [7,8-11,12]=4.0 mohm Nom, [1-6]= 300 mohm Max
 - Inductance [2-5] = 65 uH Nom, 48 uH Min 100KHz, 1 VRMS @ 25C
 - Leakage Inductance [2-5] Short [7-11] = 30 nH Nom @100 KHz
 - Dielectric Strength [2,5] to [7-11] 1750 VDC, [1-6] to [2-5] 500VAC | [1-6],[2-5] to CORE 1750 VDC, [7-11] to CORE 500 VDC
 - Weight 16 grams Max || Pin Composition is 96/4 Sn-Ag.
 - This device is certified RoHS Compliant in materials used and construction.
 - Temperature Range: -40C to +85C operating | -55C to +155C Non-Operating

- ORDERING INFORMATION:
- Order Per Part # G45AH2-0404-04 Parts ship in trays unless otherwise specified.
 - For Tape & Reel packaging append "R" to PN, e.g. G45AH2-0404-04-R.
Tape & Reel packaging is in accordance with Champs Dwg T40-4600014.
 - Std 180 parts per reel | 40 parts per tray.

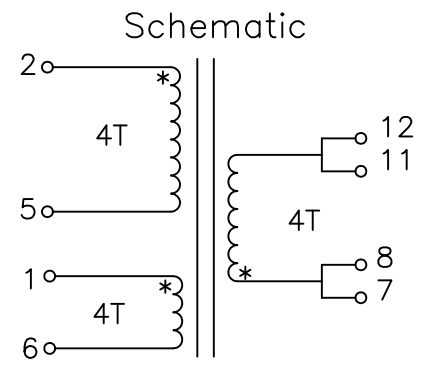

No.	DESCRIPTION	REVISIONS	DATE	APPR
THIRD ANGLE PROJECTION				
CHAMPS TECHNOLOGIES				
DRAWN		SIGN	DATE	Champs No. G45AH2 0404-04
CHKD		DK	10/26/09	Customer ISSUE A
APPR		HE	9/11/13	Part #: REV 00
SIZE			SCALE 2:1	