

## Railway Apps: 50-160Vin to 5V, 12V, 24V, 54V, 80 Vout to 240W Active Clamp Forward

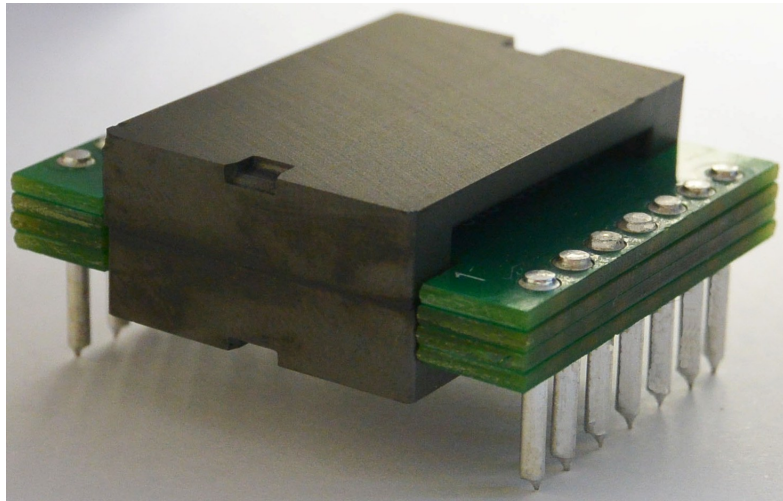

- Footprint: 31.8 wide x 36.8 mm length x 12.6 mm Height
- Proven in actual Analog / Linear Ref Design using LT3752 & LT8311 ICs.
- Optimized for Active Clamp Forward Topology.
- Typical Efficiency 94-95%
- Aggressive Interleave planar construction -- lowest achievable Leakage Inductance.
- Multilayer PCB optimization for lowest AC resistance & Proximity Loss Effect.
- Wide variety of PNs, Designs and Turns Ratios in stock. If not listed, Contact Us.
- Integer Turns 1 thru 16 Available [Contact Us if Not Shown in Table].
- Available with Thermal Pad or Heat Sink.
- Surface Mount, Thru-Hole, Pad-to-Pad, Embedded Planar Windings as Options.

Table I: 80R6 & P26R6 Series 50-180 Vin Rated to 240W Output.

Champs PN	Vin (Min)	Vin (Max)	Vout	Iout (A dc)	Pout (Watts)	Freq (KHz)	Output Inductor PN
80R6-0806-150R	50	160	24	10.0	240	100-200	PQI26-33R-LTC
P26R6-0806-03-150R	50	160	24	10.0	240	100-200	PQI26-33R-LTC
80R6-0803-150R	50	160	12.0	20.0	240	100-200	PQI2050-08-HX
P26R6-0803-03-150R	50	160	12.0	20.0	240	100-200	PQI2050-08-HX

80R61302-250R	50	150	5.0	40.0	200	100-200	PQI2050-2R0-HX
80R6-1402-250R	60	180	5.0	40.0	200	100-200	PQI2050-2R0-HX
80R6-0814-S02	50	150	54	3.0	162	100-200	PQI26-330-LTC
P26R6-0814-02-S01	50	150	54	3.0	162	100-200	PQI26-330-LTC
80R6-1020-300R	60	150	80	3.0	240	100-200	PQI26-330-LTC
80R6-2012-1M2	130	250	50.0	4.0	200	100-200	PQI26-130-LTC

## Baseline Reference Design:

<https://www.analog.com/en/design-center/reference-designs/circuit-collections/lt3752-75v-to-150v-24v-14a-340w-no-opto-active-clamp-isolated-forward-converter.html#cc-overview>

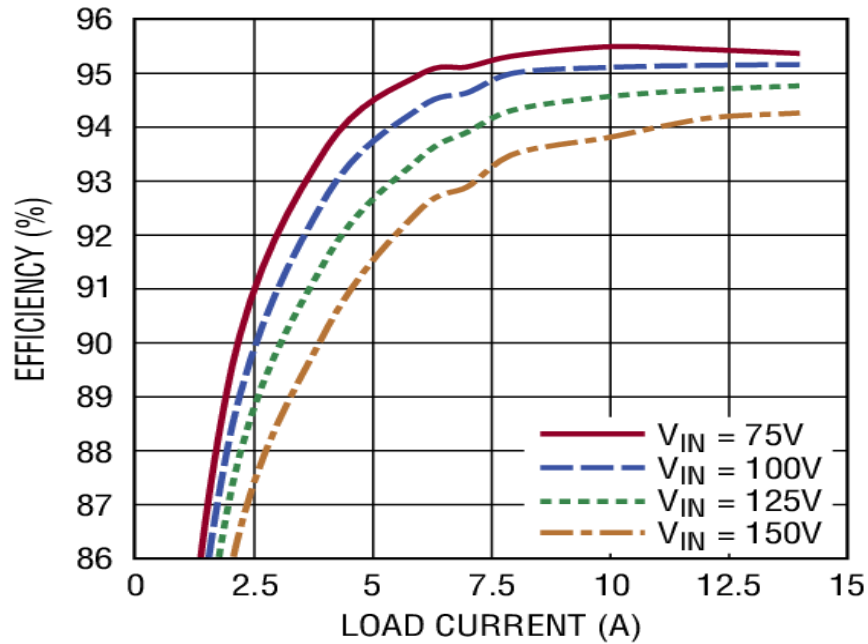

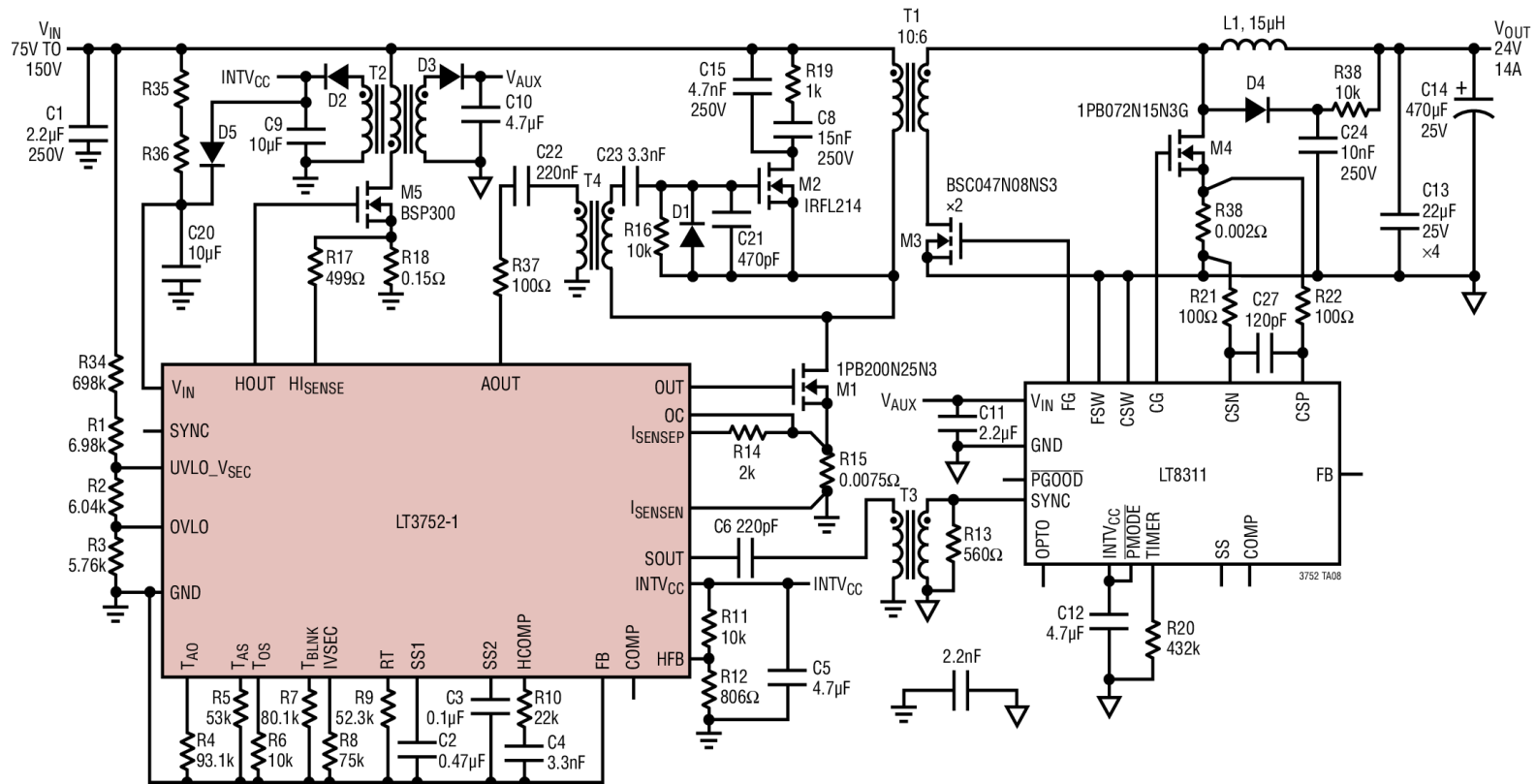

- T1: CHAMPS LT80R2-12AC-1006
- T2: WÜRTH 750817020
- T3: PULSE PE-68386NL
- T4: ICE GT05-111-100
- L1: COILCRAFT AGP2923-153
- D1, D2, D3, D4: BAS516
- D5: CENTRAL SEMI CMMR1U-02

## Reference Design Schematic

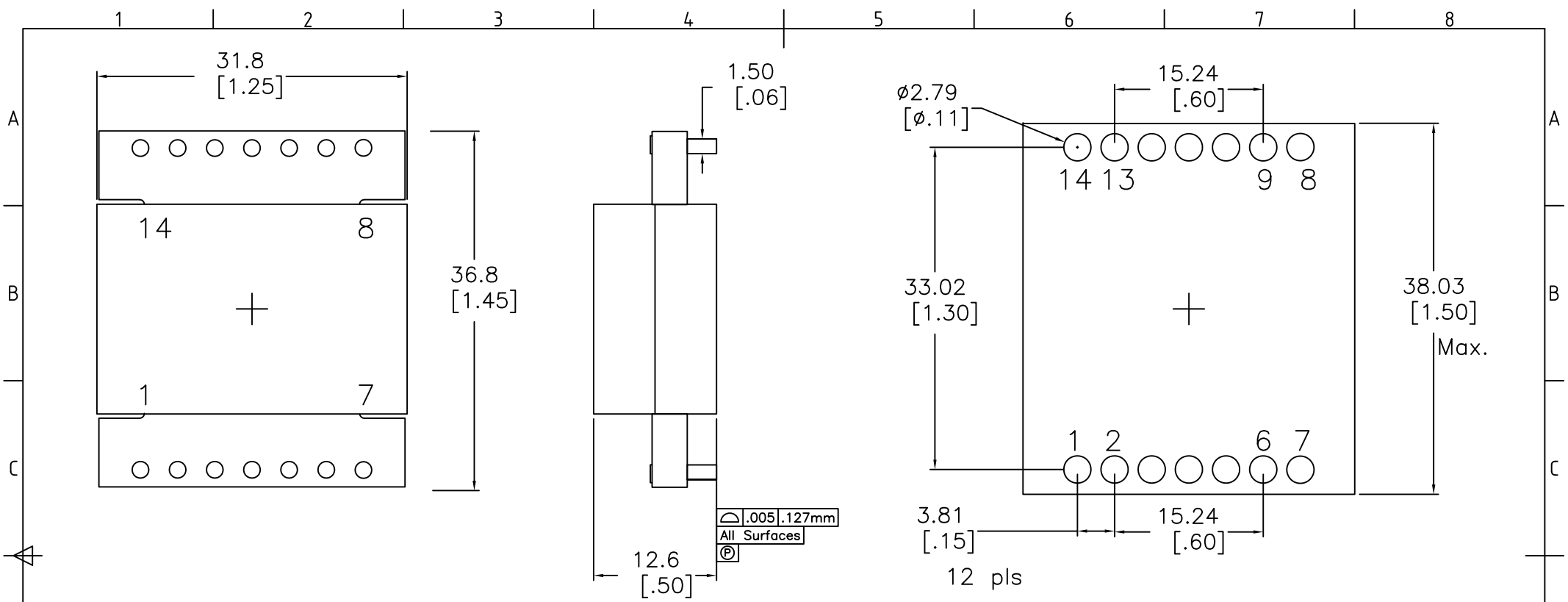

Electrical Information:

1. TURNS Ratio [9-13] : [2-6] = 0.375 +/--2%
2. INDUCTANCE [2-6] = 150 uH Nom @100kHz/1.0V
3. LEAKAGE INDUCTANCE [2-6] : SHORT 9,11 = 500 nH Max @100kHz
4. DCR [2-6] = 11 mohms Nom, DCR [9-13] = 1.73 mohms Nom, DCR [1-7] = [8-14] = 50 mohm max
5. CAPACITANCE 2,6 to 9,13 = 380 pF Max @100kHz
6. DIELECTRIC ISOLATION: [2,6],[1,7] : [9,13] > 2500 Vrms  
DIELECTRIC ISOLATION: [9,13] : CORE > 500 Vdc
7. RoHS Level 6/6 Compliant | Pins 96/4 Sn/Ag Plating
8. Operating Temp Range: -55C To +130C [Inclusive of Temp Rise]

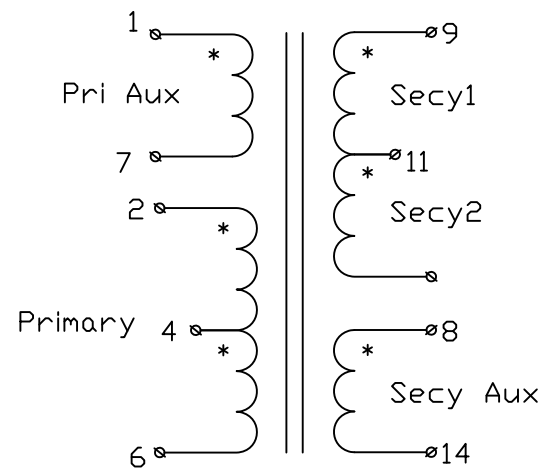

					CHAMPS TECHNOLOGIES	TOLERANCES UNLESS OTHERWISE INDICATED .xxx ± .25 .xx ± .51 ANGLE ± 1.0	DRAWN	JL	7/9/15	TITLE: 80R6-0803-150R		ISSUE	REV
							CHKD	PH			SIZE	SCALE 2:1	A
No.	DESCRIPTION	REVISIONS	DATE	APPR			APPR	DT					

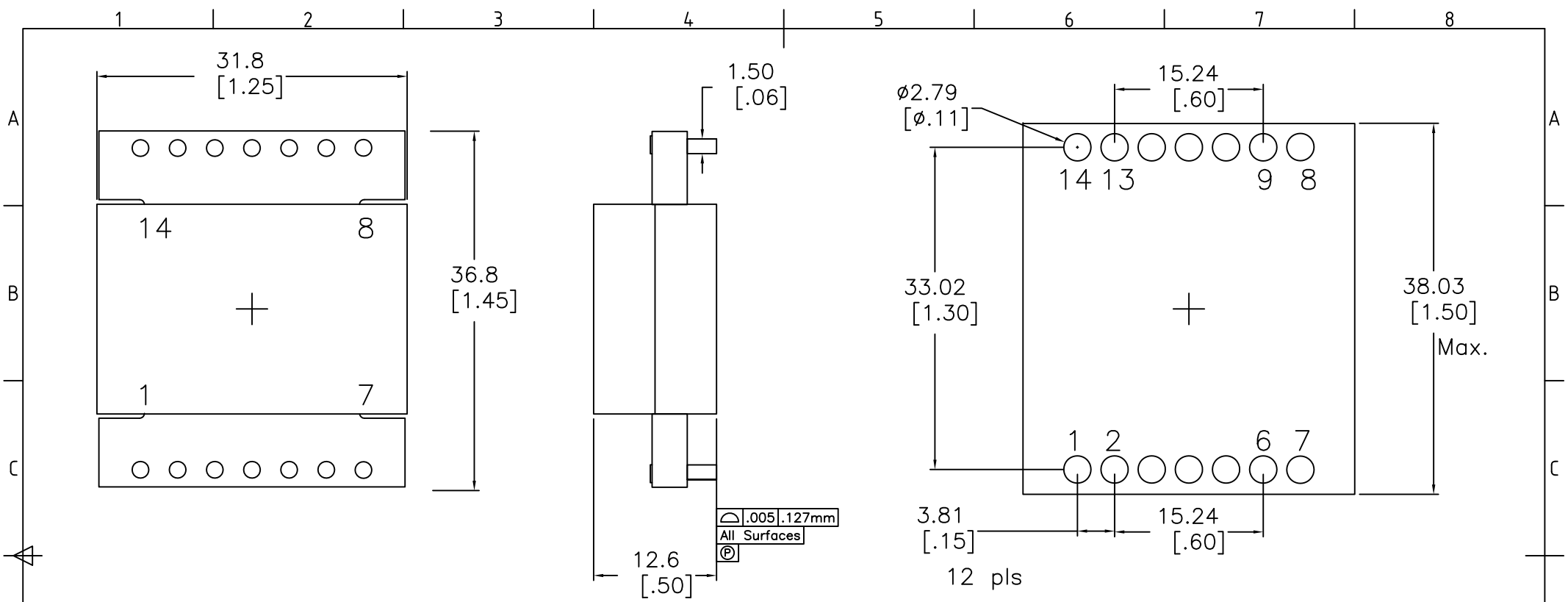

Electrical Information:

1. TURNS RATIO [9-13] : [2-6] = 0.75 +/-2%
2. INDUCTANCE [2-6] = 150 uH Nom @100kHz/1.0V
3. LEAKAGE INDUCTANCE [2-6] : SHORT 9,11 = 500 nH Max @100kHz
4. DCR [2-6] = 11 mohms Nom, DCR [9-13] = 6.9 mohms Nom,  
DCR [1-7] = [8-14] = 300 mohm max
5. CAPACITANCE 2,6 to 9,13 = 180 pF Max @100kHz
6. DIELECTRIC ISOLATION: [2,6],[1,7] : [9,13] > 2500 Vrms  
DIELECTRIC ISOLATION: [9,13] : CORE > 500 Vdc
7. RoHS Level 6/6 Compliant | Pins 96/4 Sn/Ag Plating
8. Operating Temp Range: -55C To +130C [Inclusive of Temp Rise]

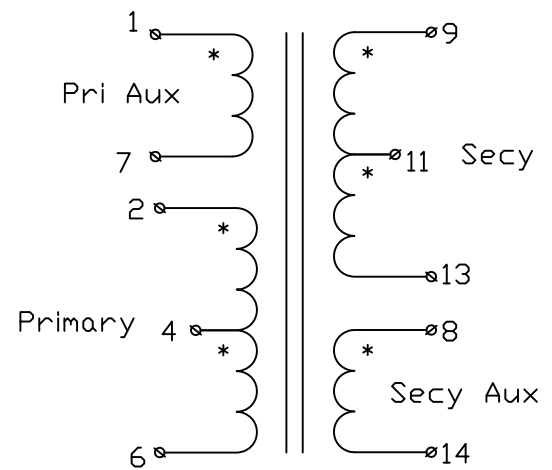

					CHAMPS TECHNOLOGIES	TOLERANCES UNLESS OTHERWISE INDICATED .xxx ± .25 .xx ± .51 ANGLE ± 1.0	DRAWN	JL	7/9/15	TITLE: 80R6-0806-150R		ISSUE	REV
							CHKD	PH			SIZE	SCALE 2:1	A
No.	DESCRIPTION	REVISIONS	DATE	APPR			APPR	DT					

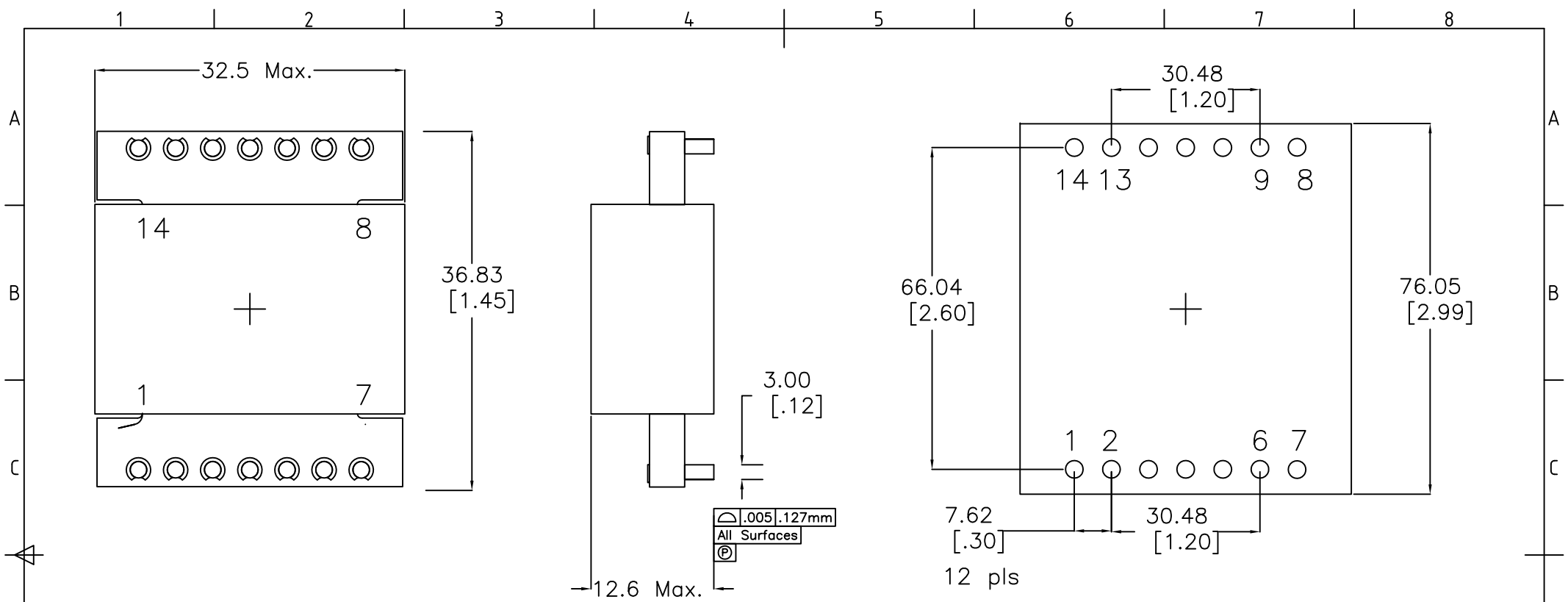

Electrical Information:

1. TURNS RATIO [2-6] : [9-13] = 0.571 +/-2% || [8-14] : [9-13] = 0.143
2. INDUCTANCE [2-6] = 342 uH Nom, 258 Min @100kHz/1.0V
3. LEAKAGE INDUCTANCE [2-6] : SHORT 9-13 = 250nH Nom @100kHz
4. DCR [2-6] = 11 mohms Nom, DCR [9-13] = 37 mohms Nom, DCR [8-14] = 300 mohm max
5. CAPACITANCE 2,6 to 9,13 = 120 pF Nom @100kHz
6. DIELECTRIC ISOLATION: [2,6] : [9,13], [[8,14] > 2500 Vrms  
DIELECTRIC ISOLATION: [9,13} : [8.14] : CORE > 500 Vdc
7. RoHS Level 6/6 Compliant | Pins 96/4 Sn/Ag Plating

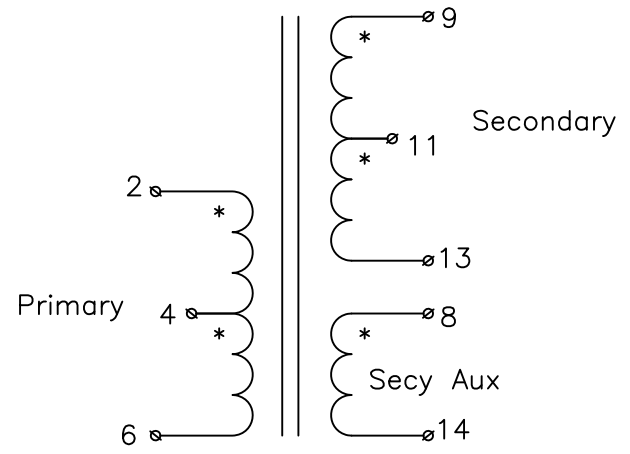

APPLICATION 50-150VIN TO 54VOUT @3.0A FORWARD

					CHAMPS TECHNOLOGIES	TOLERANCES UNLESS OTHERWISE INDICATED .XXX ± .XX ± ANGLE ±	DRAWN	JL	1/27/15	TITLE: 80R6-0814-S02		ISSUE	REV
							CHKD	PH			SIZE	SCALE 2:1	A
No.	DESCRIPTION	REVISIONS	DATE	APPR			APPR	DT					

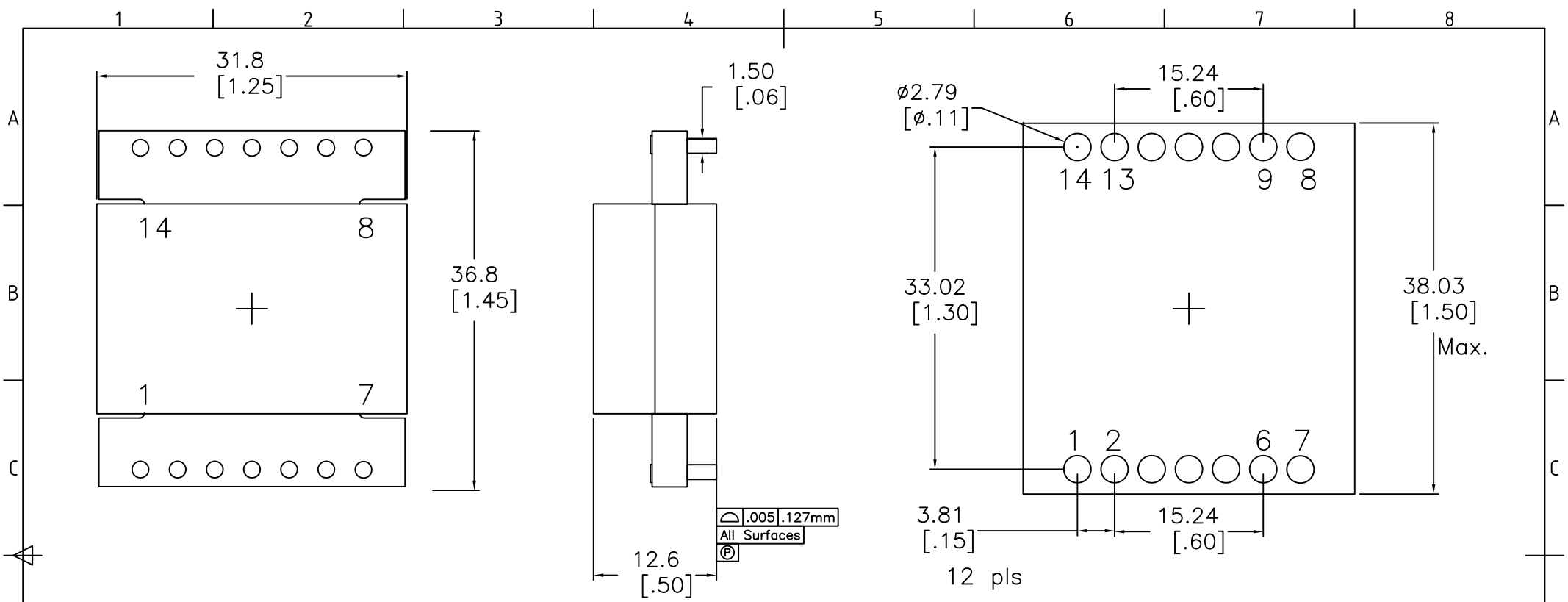

Electrical Information:

1. TURNS RATIO [2-6] : [9-13] = 0.50 +/-2% || [1-7] = [8-14] : [2-6] = 'TBD'
2. INDUCTANCE [2-6] = 300 uH Nom @100kHz/1.0V
3. LEAKAGE INDUCTANCE [2-6] : SHORT 9,11 = 1.0 uH Max @100kHz
4. DCR [2-6] = 19.7 mohms Nom, DCR [9-13] = 77 mohms Nom, DCR [1-7] = [8-14] = 300 mohm max
5. CAPACITANCE 2,6 to 9,13 = 180 pF Max @100kHz
6. DIELECTRIC ISOLATION: [2,6],[1,7] : [9,13] > 2500 Vrms  
DIELECTRIC ISOLATION: [9,13] : CORE > 500 Vdc
7. RoHS Level 6/6 Compliant | Pins 96/4 Sn/Ag Plating
8. Operating Temp Range: -55C To +130C [Inclusive of Temp Rise]

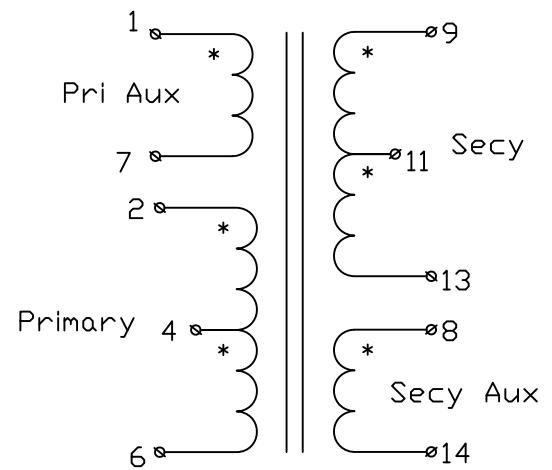

					CHAMPS TECHNOLOGIES	TOLERANCES UNLESS OTHERWISE INDICATED .XXX ± .25 .XX ± .51 ANGLE ± 1.0	DRAWN	JL	7/8/15	TITLE: 80R6-1020-300R		ISSUE	REV
							CHKD	PH			SIZE	SCALE 2:1	A
No.	DESCRIPTION	REVISIONS	DATE	APPR			APPR	DT					

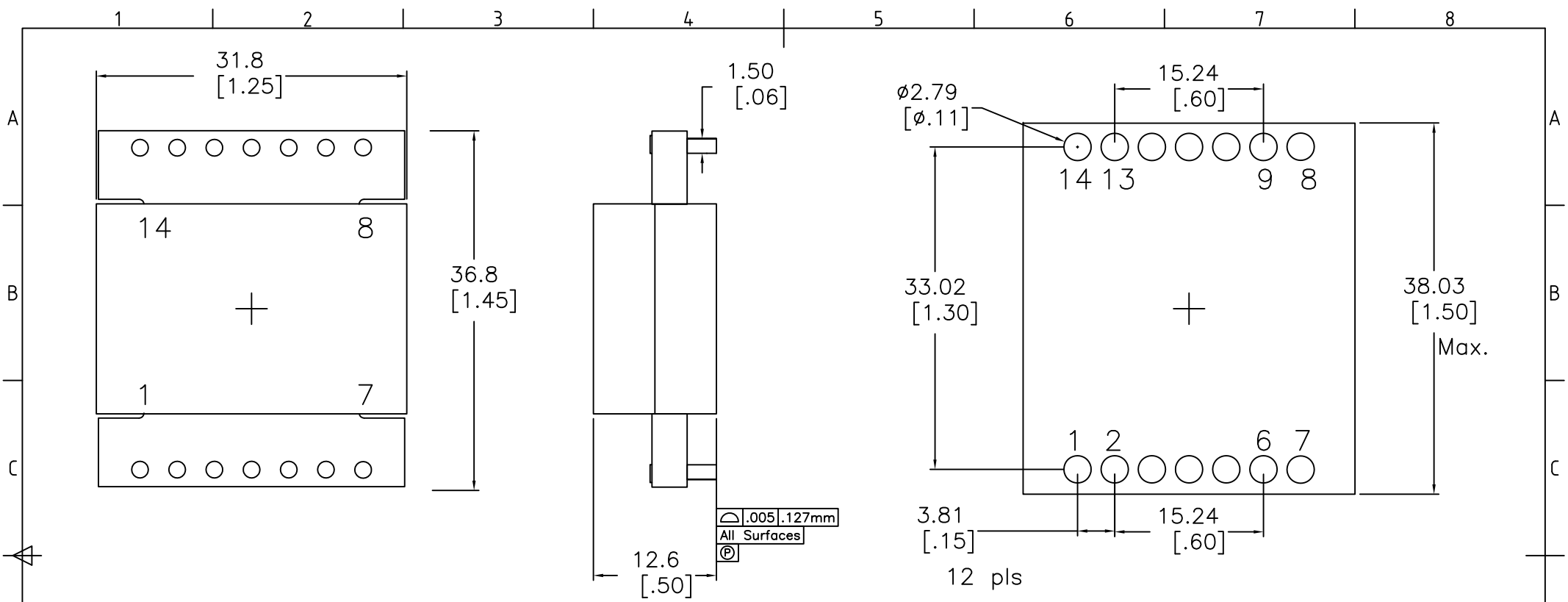

Electrical Information:

1. TURNS RATIO [9-13] : [2-6] = 0.154 +/-2% || [1-7] = [8-14] : [2-6] = 'TBD'
2. INDUCTANCE [2-6] = 250 uH Nom @100kHz/1.0V
3. LEAKAGE INDUCTANCE [2-6] : SHORT 9,11 = 1.0 uH Max @100kHz
4. DCR [2-6] =33 mohms Nom, DCR [9-13] = 0.69 mohms Nom, DCR [1-7] = [8-14] = 300 mohm max
5. CAPACITANCE 2,6 to 9,13 = 180 pF Max @100kHz
6. DIELECTRIC ISOLATION: [2,6],[1,7] : [9,13] > 2500 Vrms  
DIELECTRIC ISOLATION: [9,13] : CORE > 500 Vdc
7. RoHS Level 6/6 Compliant | Pins 96/4 Sn/Ag Plating
8. Operating Temp Range: -55C To +130C [Inclusive of Temp Rise]

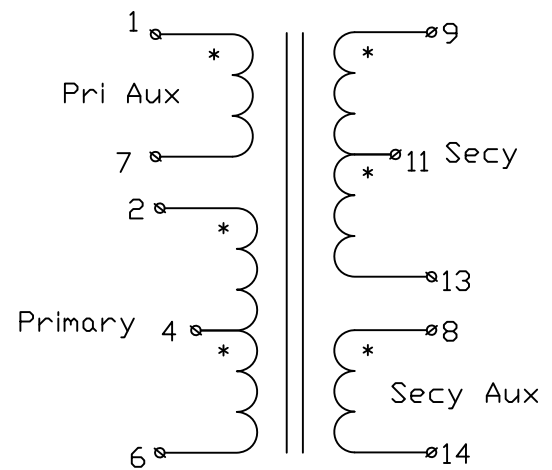

					CHAMPS TECHNOLOGIES	TOLERANCES UNLESS OTHERWISE INDICATED .xxx ± .25 .xx ± .51 ANGLE ± 1.0	DRAWN	JL	7/9/15	TITLE: 80R6-1302-250R		ISSUE	REV
							CHKD	PH			SIZE	SCALE 2:1	A
No.	DESCRIPTION	REVISIONS	DATE	APPR			APPR	DT					



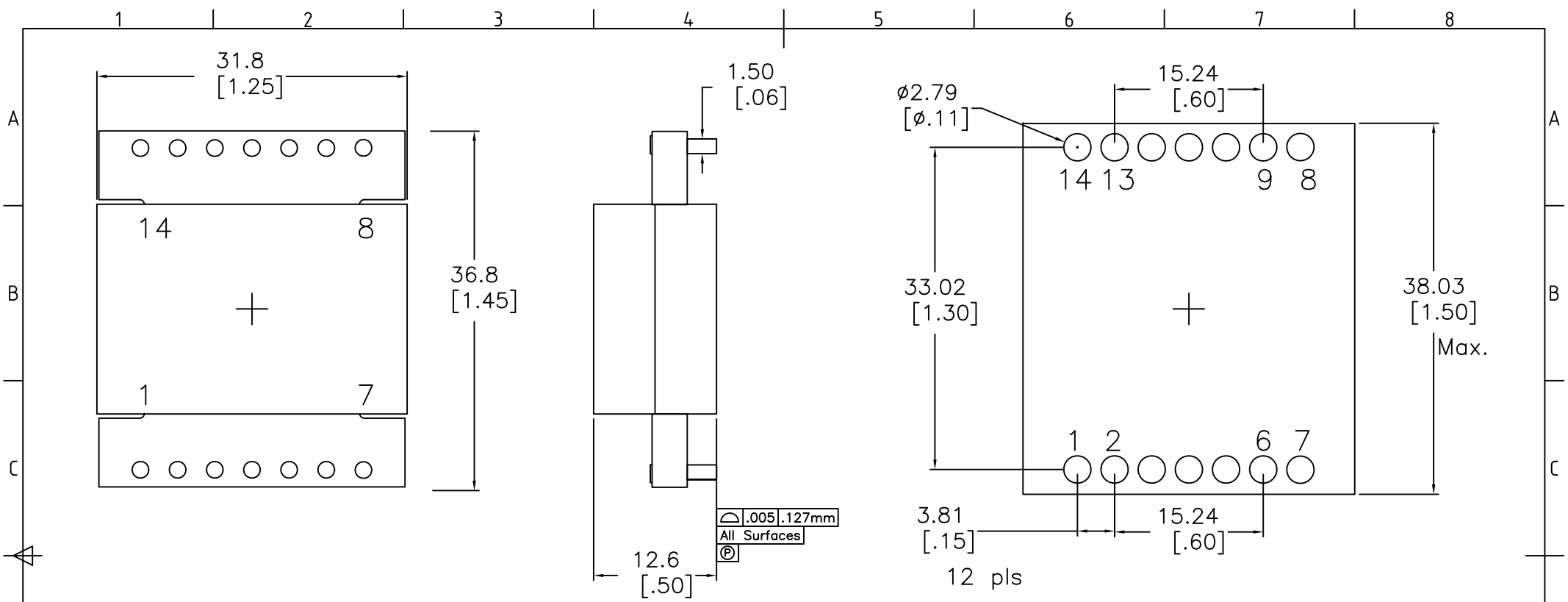

Electrical Information:

1. TURNS RATIO [9-13] : [2-6] = 0.143 +/-2% || [1-7] = [8-14] : [2-6] = 'TBD'
2. INDUCTANCE [2-6] = 250 uH Nom @100kHz/1.0V
3. LEAKAGE INDUCTANCE [2-6] : SHORT 9,11 = 1.0 uH Max @100kHz
4. DCR [2-6] =33 mohms Nom, DCR [9-13] = 0.69 mohms Nom, DCR [1-7] = [8-14] = 300 mohm max
5. CAPACITANCE 2,6 to 9,13 = 180 pF Max @100kHz
6. DIELECTRIC ISOLATION: [2,6],[1,7] : [9,13] > 2500 Vrms  
DIELECTRIC ISOLATION: [9,13] : CORE > 500 Vdc
7. RoHS Level 6/6 Compliant | Pins 96/4 Sn/Ag Plating
8. Operating Temp Range: -55C To +130C [Inclusive of Temp Rise]

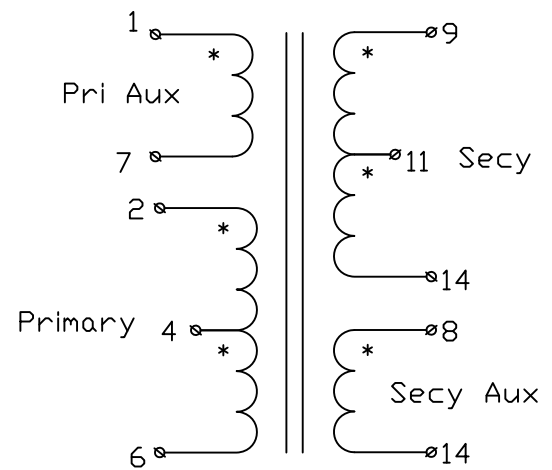

					CHAMPS TECHNOLOGIES	TOLERANCES UNLESS OTHERWISE INDICATED .xxx ±.25 .xx ±.51 ANGLE ±1.0	DRAWN	JL	7/9/15	TITLE: 80R6-1402-250R		ISSUE	REV
							CHKD	PH			SIZE	SCALE 2:1	A
No.	DESCRIPTION	REVISIONS	DATE	APPR			APPR	DT					

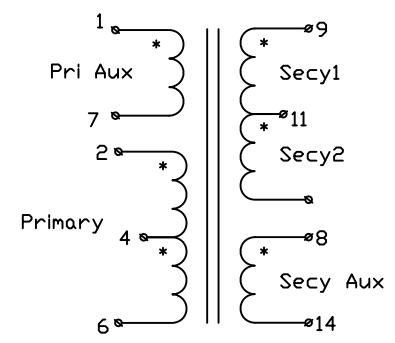
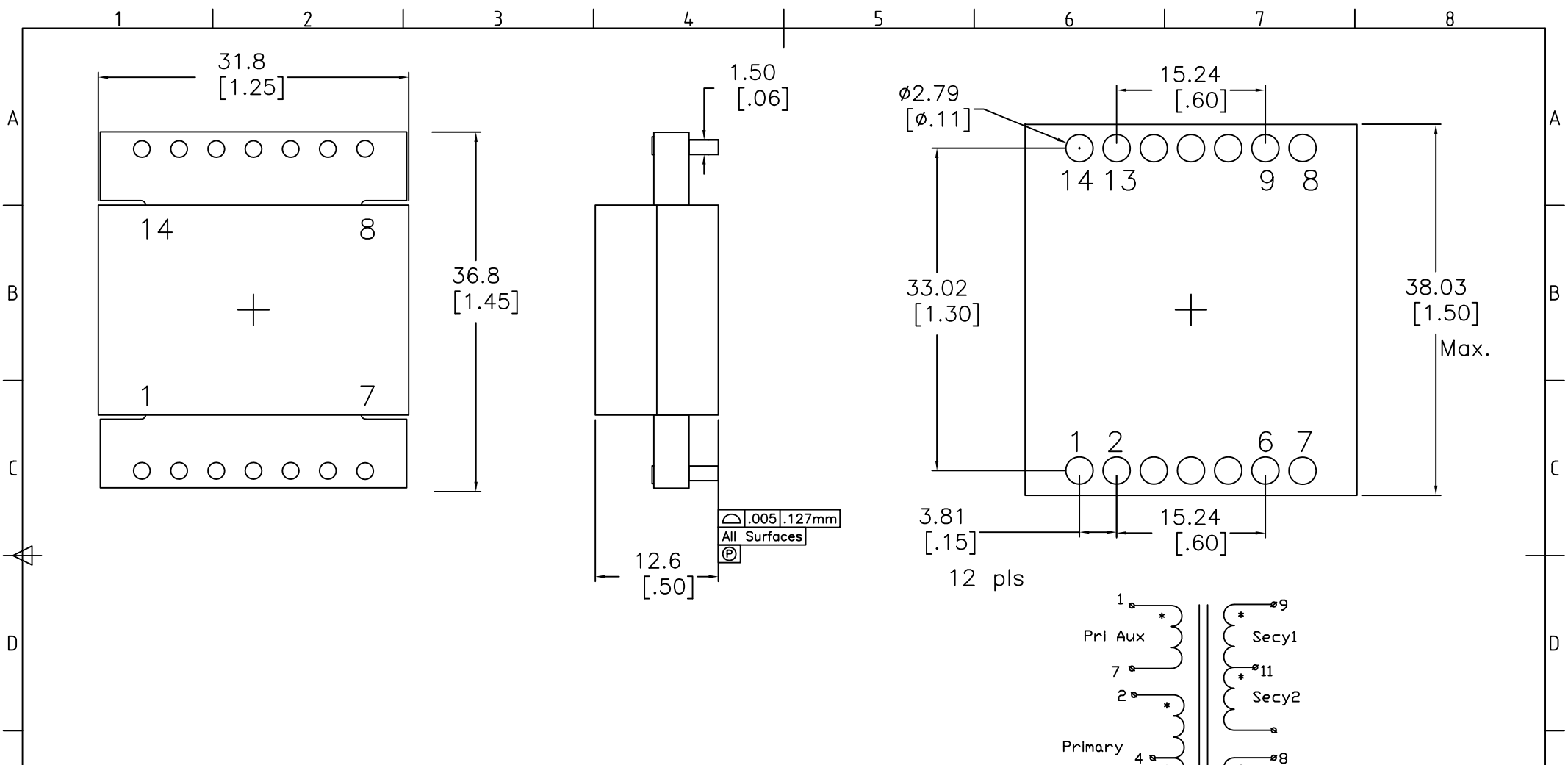

Electrical Information:

1. TURNS RATIO [9-13] : [2-6] = 0.6 ±2%
2. INDUCTANCE [2-6] = 1200 uH Nom ±10% @100kHz/1.0V
3. LEAKAGE INDUCTANCE [2-6] : SHORT 9,11 = 850 nH Max @100kHz
4. DCR [2-6] = 77 mohms Nom, DCR [9-13] = 28.5 mohms Nom, DCR [1-7] = [8-14] = 300 mohm max
5. CAPACITANCE 2,6 to 9,13 = 180 pF Max @100kHz
6. DIELECTRIC ISOLATION: [2,6],[1,7] : [9,13] > 2500 Vrms  
DIELECTRIC ISOLATION: [9,13] : CORE > 500 Vdc
7. RoHS Level 6/6 Compliant | Pins 96/4 Sn/Ag Plating
8. Operating Temp Range: -55C To +130C [Inclusive of Temp Rise]

No.	DESCRIPTION	REVISIONS	DATE	APPR
THIRD ANGLE PROJECTION				
CHAMPS TECHNOLOGIES				
TOLERANCES/UNITS in MM UNLESS OTHERWISE INDICATED		SIGN	DATE	Champs-Tech PN 80R6-2012-1M2
.XXX ± .25	DRAWN	JL	03.05.15	Customer   ISSUE
.XX ± .51	CHKD	PH		Part #:   A
.X ± 1.0	APPR	DT		REV 00
ANGLE ±			SIZE	SCALE 2:1

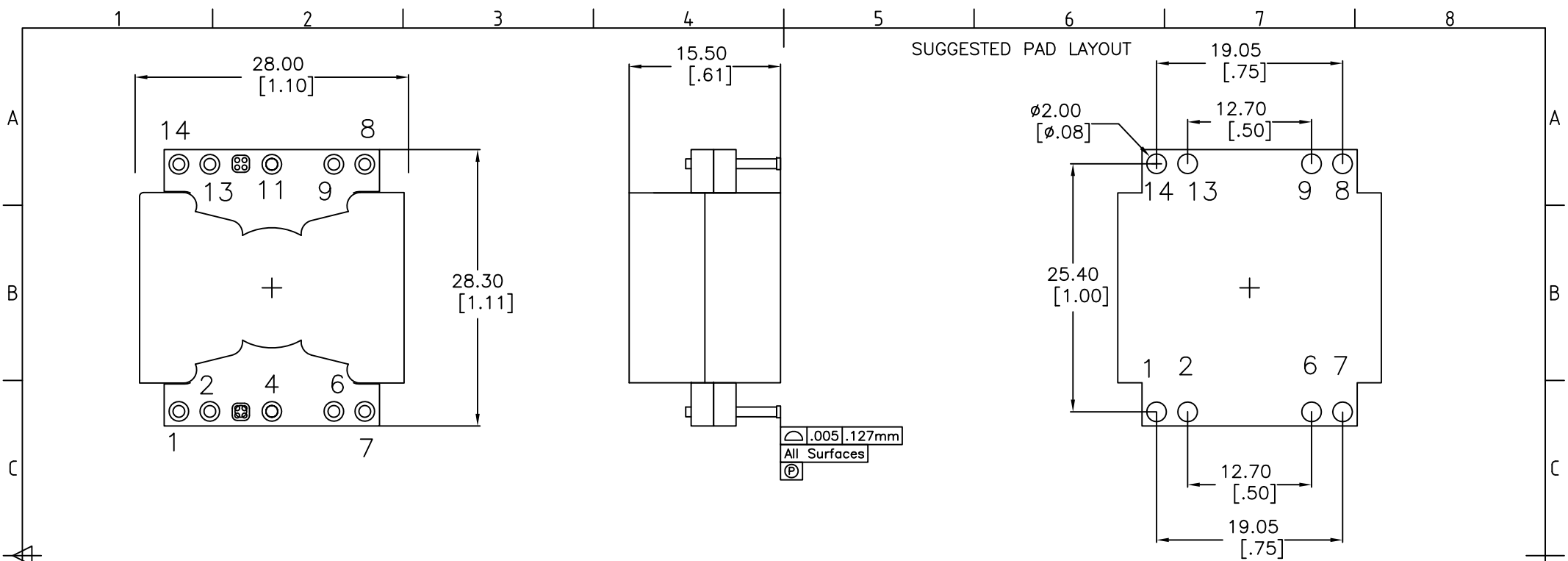

Electrical Information:

1. TURNS RATIO [9-13] : [2-6] = 0.375 +/-2% || [1-7] : [2-6] = 0.375
2. INDUCTANCE [2-6] = 150 uH Nom +/-10% @100kHz/1.0V
3. LEAKAGE INDUCTANCE [2-6] : SHORT 9,13 = 150 nH Max @100kHz
4. DCR [2-6] = 25 mohms Nom, DCR [9-13] = 4 mohms Nom, DCR [1-7] = [8-14] = 50 mohm max
5. CAPACITANCE 2,6 to 9,13 = 450 pF Max @100kHz
6. DIELECTRIC ISOLATION: [2,6],[1,7] : [9,13] > 2500 Vrms  
DIELECTRIC ISOLATION: [9,13] : CORE > 500 Vdc
7. RoHS Level 6/6 Compliant | Pins 96/4 Sn/Ag Plating
8. Operating Temp Range -55C to +130C [Inclusive of Application Temp Rise]
9. Storage Temp Range -55C to +130C [Materials rated to +170C]

Schematic

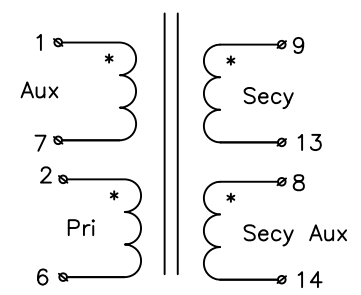

No.	DESCRIPTION	REVISIONS	DATE	APPR
THIRD ANGLE PROJECTION				
CHAMPS TECHNOLOGIES				
TOLERANCES +/- 1.0 UNLESS OTHERWISE INDICATED		SIGN	DATE	Champs No. P26R6-0803-03-150R
.XXX ±	DRAWN	JL	12/2/14	Customer
.XX ±	CHKD	PH		Part #:
.X	APPR	DT		ISSUE A
ANGLE ±				REV 00
			SIZE	SCALE 2:1

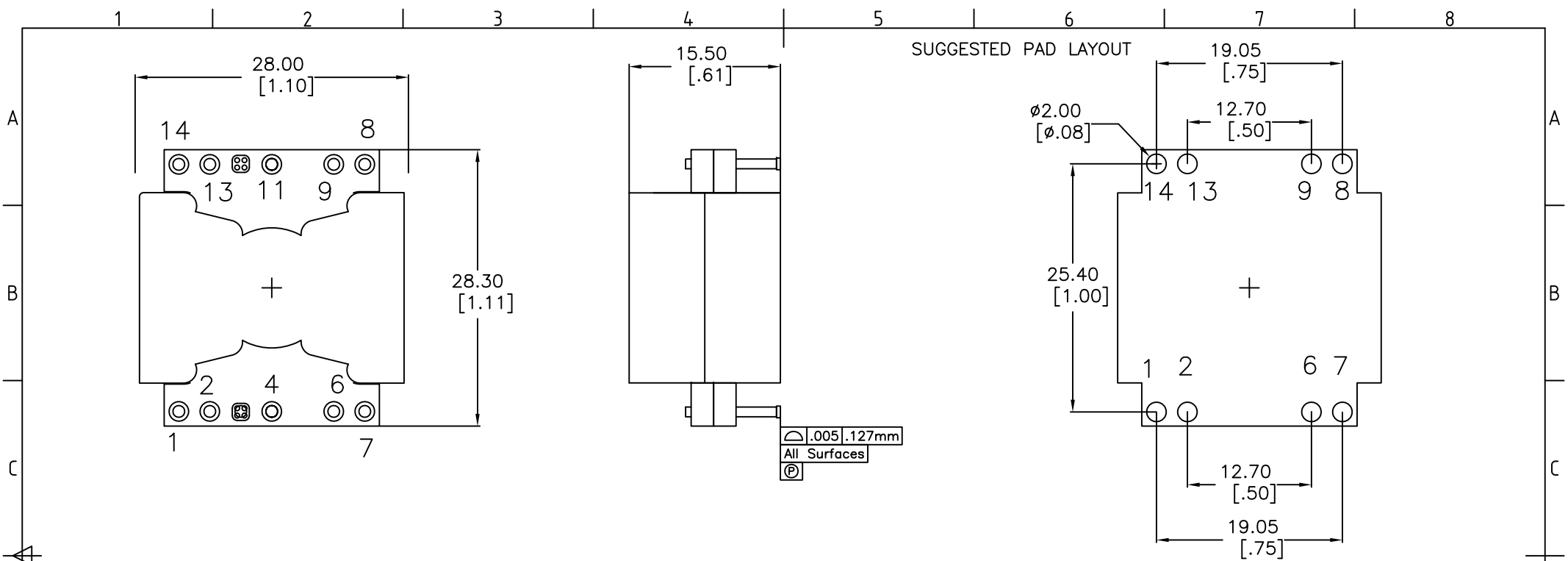

Electrical Information:

1. TURNS RATIO [9-13] : [2-6] = 0.75 +/-2% || [1-7] : [2-6] = 0.375
2. INDUCTANCE [2-6] = 150 uH Nom +/-10% @100kHz/1.0V
3. LEAKAGE INDUCTANCE [2-6] : SHORT 9,13 = 150 nH Max @100kHz
4. DCR [2-6] = 35 mohms Nom, DCR [9-13] = 15 mohms Nom, DCR [1-7] = [8-14] = 50 mohm max
5. CAPACITANCE 2,6 to 9,13 = 450 pF Max @100kHz
6. DIELECTRIC ISOLATION: [2,6],[1,7] : [9,13] > 2500 Vrms  
DIELECTRIC ISOLATION: [9,13] : CORE > 500 Vdc
7. RoHS Level 6/6 Compliant | Pins 96/4 Sn/Ag Plating
8. Operating Temp Range -55C to +130C [Inclusive of Application Temp Rise]
9. Storage Temp Range -55C to +130C [Materials rated to +170C]

Schematic

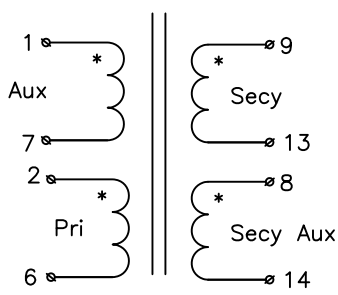

No.	DESCRIPTION	REVISIONS	DATE	APPR
CHAMPS TECHNOLOGIES				
DRAWN		SIGN	DATE	Champs No. P26R6-0806-03-150R
CHKD		PH	12/2/14	Customer   ISSUE A   REV 00
APPR		DT	SIZE	SCALE 2:1

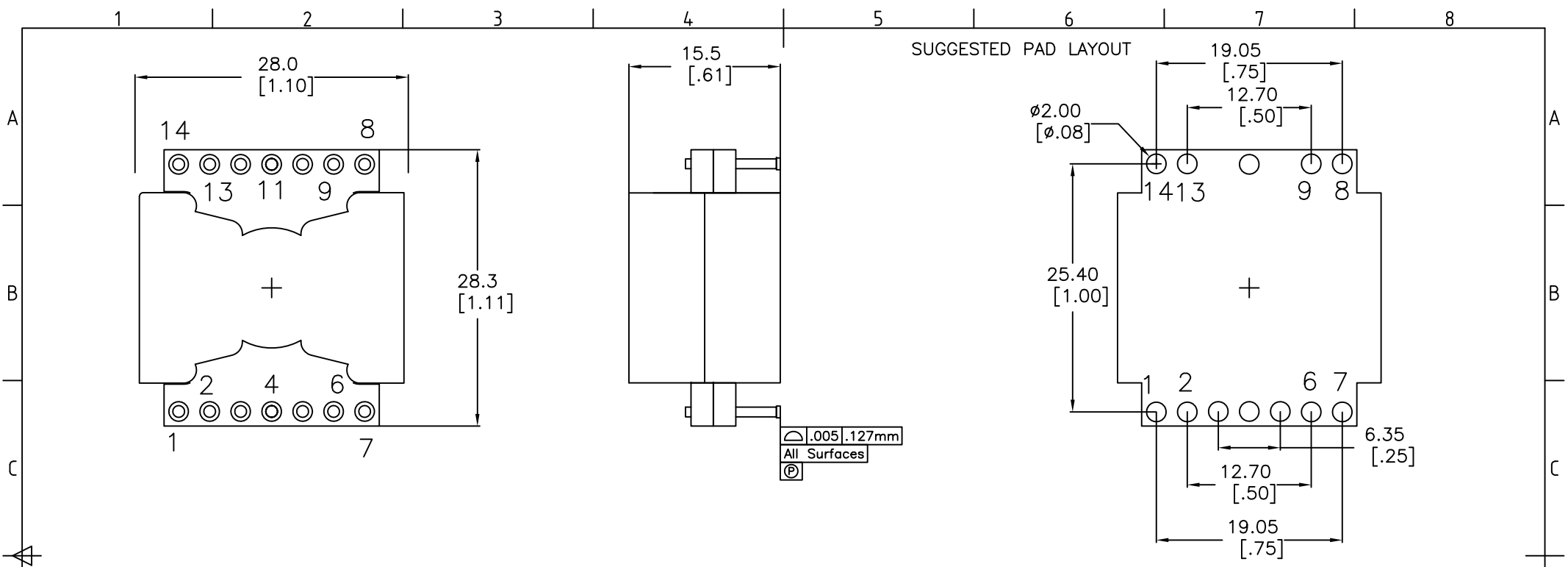

Electrical Information:

1. TURNS RATIO [2-6] : [9-13] 0.571 +/--2%  
 TURNS RATIO [1-7] : [9-13] 0.143 +/--2% || [8-14] : [9-13] = 0.072
2. INDUCTANCE [2-6] = 384 uH Nom @100kHz/1.0V
3. LEAKAGE INDUCTANCE [2-6] : SHORT 9-13 = 200 nH Nom @100kHz
4. DCR [2-6] = 17.7 mohms Nom, DCR [9-13] = 61 mohms Nom,  
 DCR [2-6] & [8-14] = 300 mohm max
5. CAPACITANCE 2,6 to 9,13 = 130 pF Nom, 180 Max@100kHz
6. DIELECTRIC ISOLATION: [2,6]: [9,13][8,14] > 1500 VDC  
 DIELECTRIC ISOLATION: [9,13][8,14] : CORE > 500 Vdc
7. RoHS Level 6/6 Compliant | Pins 96/4 Sn/Ag Plating
8. Operating Temp Range -55C to +130C [Inclusive of Application Temp Rise]
9. Storage Temp Range -55C to +130C [Materials rated to +170C]

Schematic

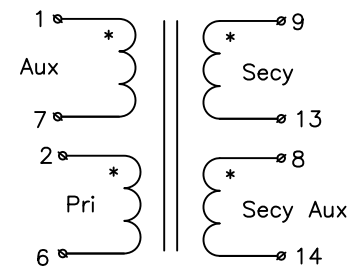

No.		DESCRIPTION		REVISIONS	DATE	APPR
THIRD ANGLE PROJECTION						
CHAMPS TECHNOLOGIES						
TOLERANCES UNLESS OTHERWISE INDICATED		SIGN	DATE	Champs No. P26R6-0814-02-S01		
.XXX ± .25	.XX ± .51	JL	05.20.15	Customer		ISSUE A
.X ± 1.0	ANGLE ±	PH		Part #:		REV 00
		APPR	DT	SIZE	SCALE 2:1	

# SUGGESTED PAD LAYOUT

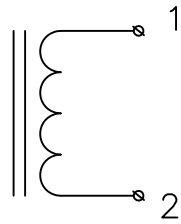
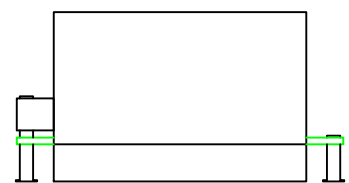
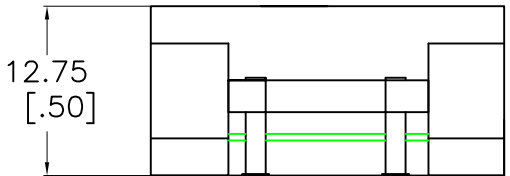
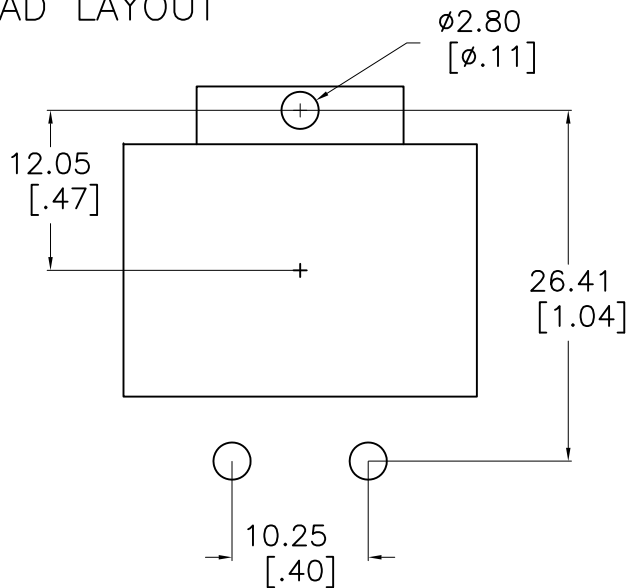
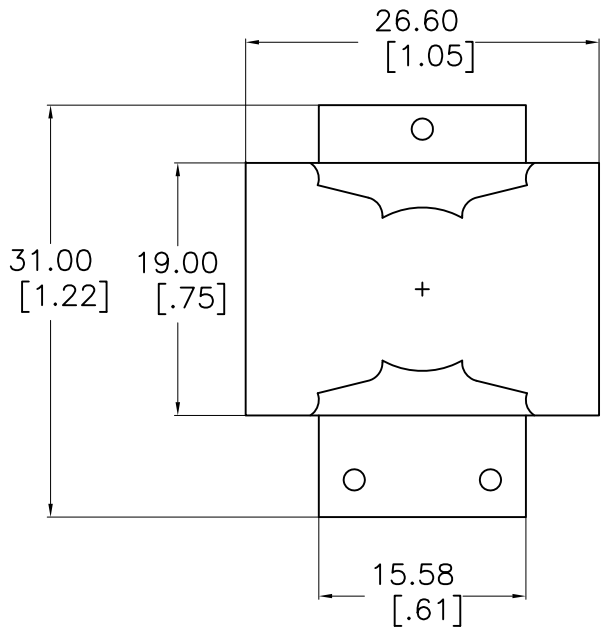

**NOTES:**

1. INDUCTANCE [1-2] = 33 uH Nom, 29.5 Min. @100kHz 1.0V 13.0A<sub>dc</sub>
2. INDUCTANCE [1-2] = 28 uH Min @100kHz 1.0V 15A<sub>dc</sub> @25C
3. DCR [1-2] = 9.0 mohms Nom, 11.0 mohms Max
4. DIELECTRIC ISOLATION > 500 VDC [1-2], : CORE
5. SATURATION CURRENT @25C = 15A<sub>dc</sub> | @100C = 14A<sub>dc</sub>
6. HEATING CURRENT FOR 45C RISE AT 25C AMBIENT = 15 A<sub>dc</sub>
7. Operating Ambient Temperature: -40C to +85C
8. RoHS Level 6/6 Compliance || 96/4 Sn/Ag Pin Composition

No.	DESCRIPTION	REVISIONS	DATE	APPR
THIRD ANGLE PROJECTION				
CHAMPS TECHNOLOGIES				
DRAWN		SIGN	DATE	Champs No. PQI26-33-LTC
CHKD				Customer   ISSUE A   REV 00
APPR			10/1/14	Part #:   SIZE   SCALE 2:1

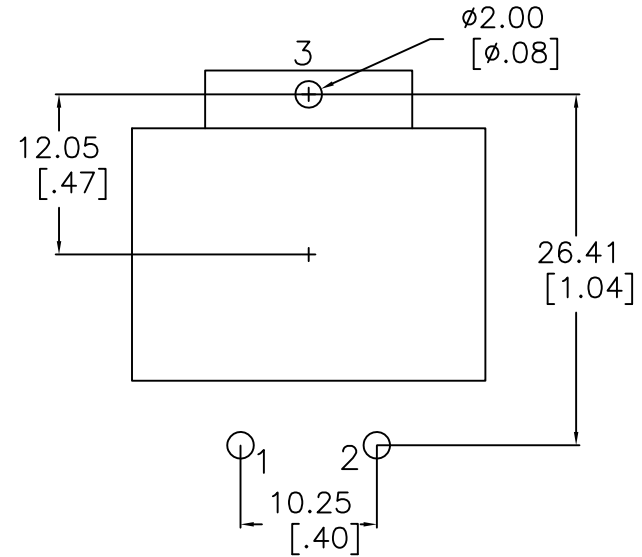
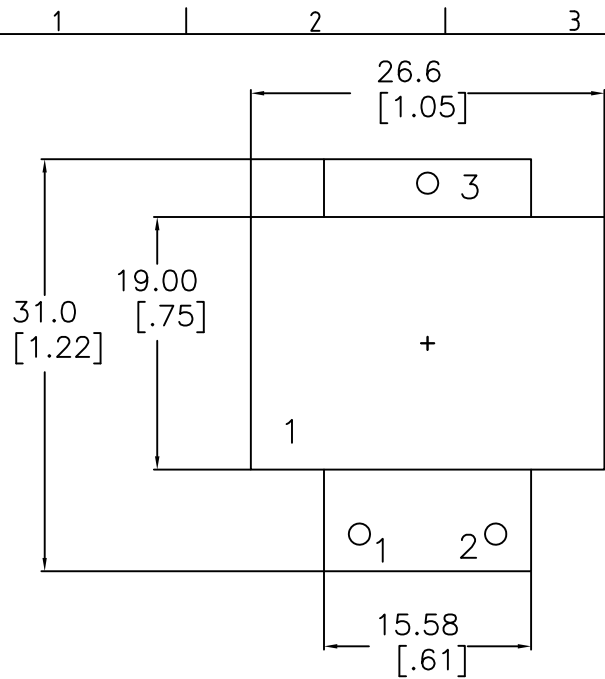

SUGGESTED THRU-HOLE LAYOUT

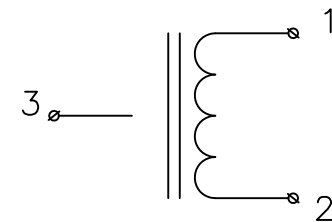
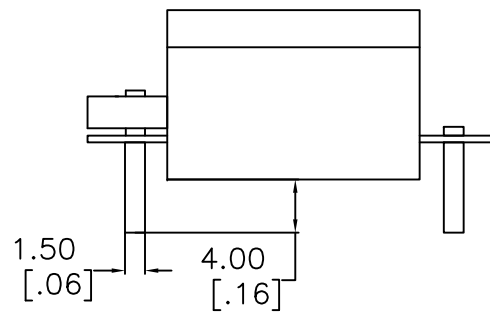
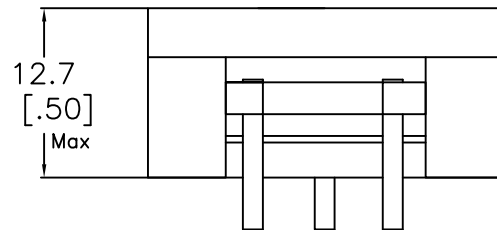

NOTES:

1. INDUCTANCE [1-2] = 130 uH Nom, ±10% @100kHz 1.0V 7.5 Adc
2. INDUCTANCE [1-2] = 110 uH Min @100kHz 1.0V 9.0 Adc @25C
3. DCR [1-2] = 35 mohms Nom, 41 Max
4. DIELECTRIC ISOLATION > 500 VDC [1-2], : CORE
5. SATURATION CURRENT @25C = 9.0 Adc | @100C = 8.0 Adc
6. HEATING CURRENT FOR 45C RISE AT 25C AMBIENT = 8.0 Adc
7. Operating Ambient Temperature: -55C to +130C [Inclusive of Temps Rise]
8. RoHS Level 6/6 Compliance || 96/4 Sn/Ag Pin Composition

No.	DESCRIPTION	REVISIONS	DATE	APPR
THIRD ANGLE PROJECTION				
CHAMPS TECHNOLOGIES				
TOLERANCES/UNITS in MM UNLESS OTHERWISE INDICATED		SIGN	DATE	Champs-Tech PN PQI26-130-LTC-TH
.XXX ± 0.254	DRAWN			Customer
.XX ± 0.508				Part #:
.X ± 0.78	CHKD		05.24.16	REV 00
ANGLE ±	APPR		SIZE	SCALE 2:1

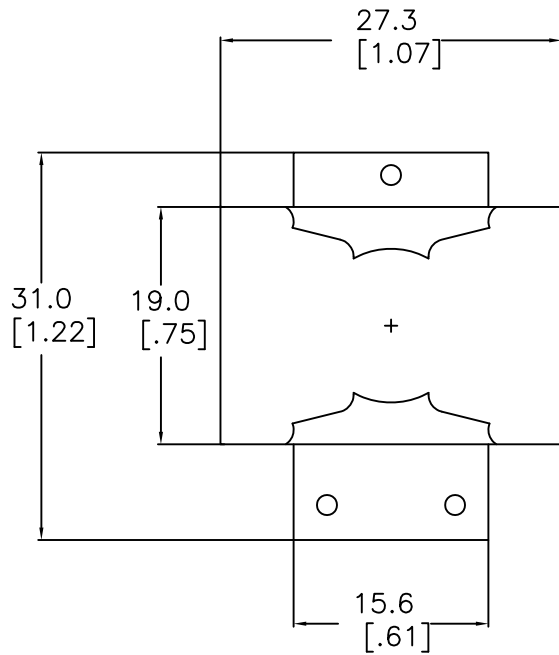

SUGGESTED PAD LAYOUT

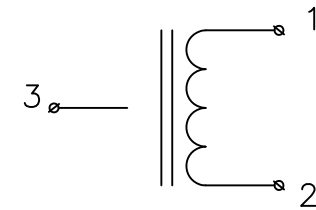
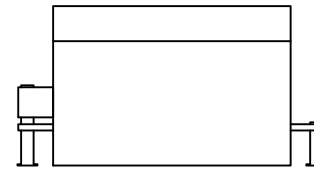
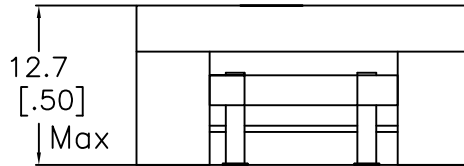
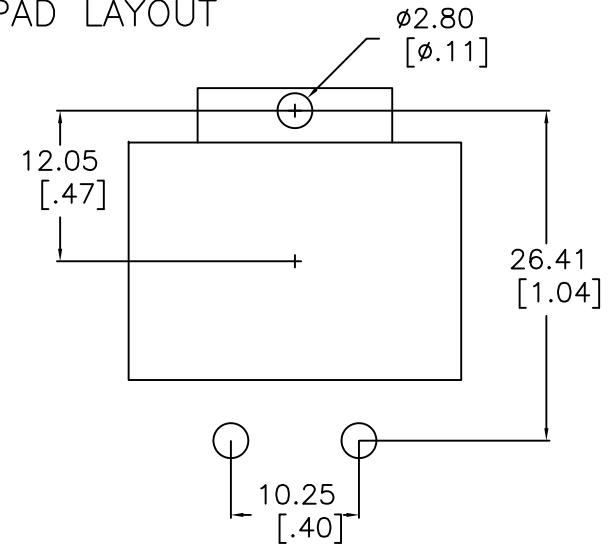

NOTES:

1. INDUCTANCE [1-2] = 330 uH Nom, ±10% @100kHz 1.0V 4.0 Adc
2. INDUCTANCE [1-2] = 280 uH Min @100kHz 1.0V 4.8 Adc @25C
3. DCR [1-2] = 69 mohms Nom, 81 Max
4. DIELECTRIC ISOLATION > 500 VDC [1-2], : CORE
5. SATURATION CURRENT @25C = 4.8 Adc | @100C = 4.0 Adc
6. HEATING CURRENT FOR 45C RISE AT 25C AMBIENT = 6 Adc
7. Operating Ambient Temperature: -55C to +130C [Inclusive of Temps Rise]
8. RoHS Level 6/6 Compliance || 96/4 Sn/Ag Pin Composition

No.	DESCRIPTION	REVISIONS	DATE	APPR
CHAMPS TECHNOLOGIES				
DRAWN		SIGN	DATE	Champs No. PQI26-330-LTC
CHKD				Customer   ISSUE
APPR			09.18.15	Part #:   A   REV
			SIZE	SCALE 2:1



1 2 3 4 5 6 7 8

A

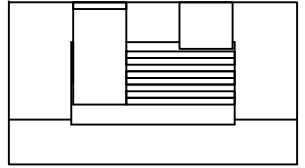

B

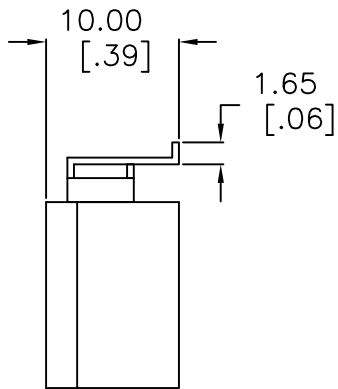
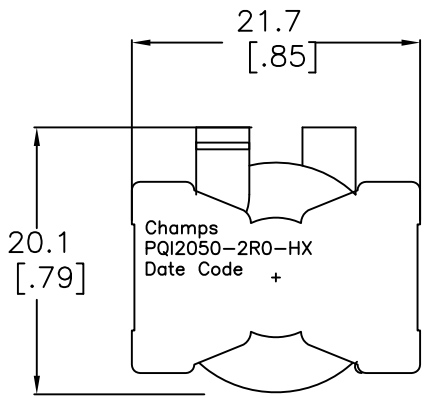

SUGGESTED PAD LAYOUT

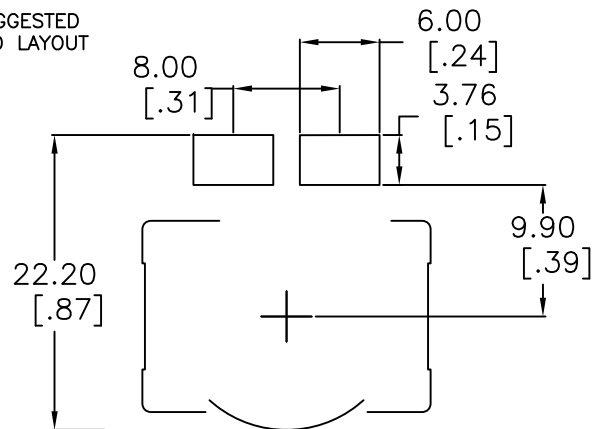

C

D

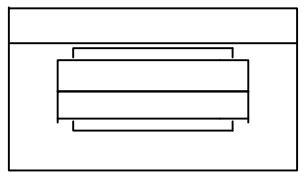

E

F

INDUCTANCE [1-2] = 2.0uH Nom, 1.80 Min. @100kHz 1.0V 40Adc  
 INDUCTANCE [1-2] = 1.65 uH Min @100kHz 1.0V 45Adc  
 DCR [1-2] = 1.00 mohms Nom, 1.25 Max  
 DIELECTRIC ISOLATION > 500 VDC [1-2] : CORE  
 SATURATION CURRENT @25C = 45.0Adc | @85C = 42.0Adc  
 HEATING CURRENT FOR 40C RISE AT 25C AMBIENT = 45 Adc

Schematic

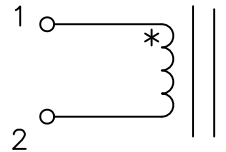

No.		DESCRIPTION		REVISIONS	DATE	APPR
THIRD ANGLE PROJECTION						
CHAMPS TECHNOLOGIES						
TOLERANCES +/- 1.0 UNLESS OTHERWISE INDICATED		SIGN	DATE	Champs No. PQI2050-2R0-HX		
.XXX ± 0.180	DRAWN	DK	3/5/15	Customer	INDUCTOR	ISSUE
.XX ± 0.38	CHKD			Part #:		REV
.X ANGLE ± 1.5	APPR	HE		SIZE	SCALE 2:1	00

1 2 3 4 5 6 7 8

A

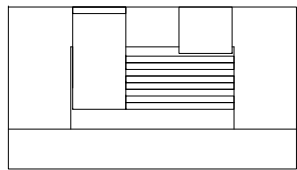

B

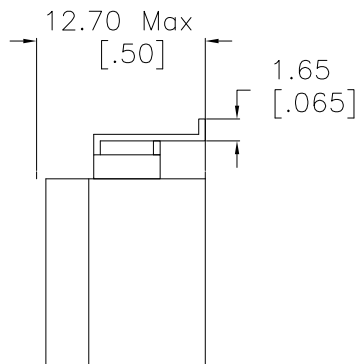
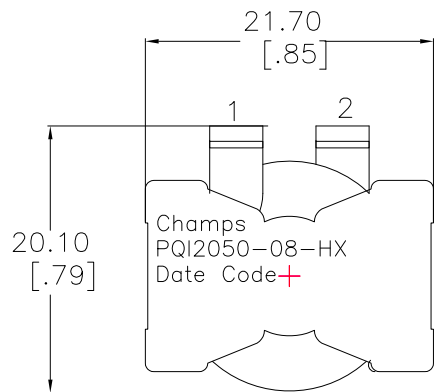

SUGGESTED PAD LAYOUT

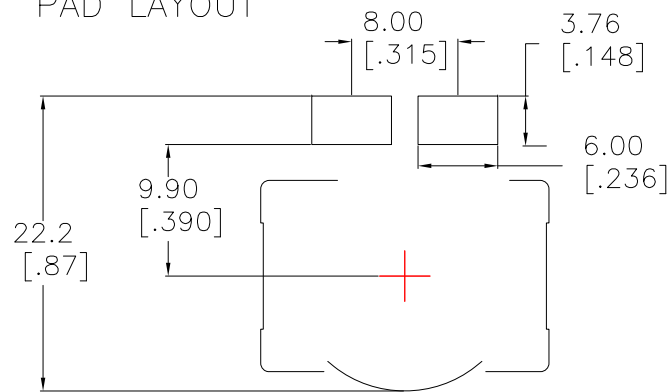

C

D

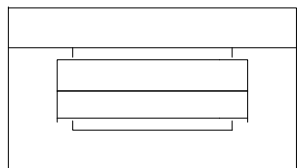

E

F

INDUCTANCE [1-2] = 8.0uH Nom, 7.0 Min. @100kHz/1.0V 20Adc  
 INDUCTANCE [1-2] = 6.35uH Min @100kHz/1.0V 23Adc  
 DCR [1-2] = 4.2 mohms Nom, 5.0 Max  
 DIELECTRIC ISOLATION > 500 VDC [1-2] : CORE  
 SATURATION CURRENT @25C = 23Adc | @85C = 21Adc  
 HEATING CURRENT FOR 40C RISE AT 25C AMBIENT = 22Adc

Schematic

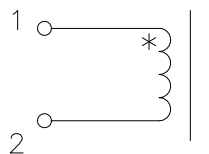

No.		DESCRIPTION		REVISIONS	DATE	APPR
THIRD ANGLE PROJECTION						
CHAMPS TECHNOLOGIES						
TOLERANCES +/- 1.0 UNLESS OTHERWISE INDICATED		SIGN	DATE	Champs No. PQI2050-08-HX		
.XXX ±	CHKD	DK	3/31/10	Customer	INDUCTOR	ISSUE A
.XX ±	APPR	HE	8/27/13	Part #:	SCALE 2:1	REV 00
.X ANGLE ±			SIZE			